

Statement of Performance

Furon® Q-Valve Reliability in 37% HCl

Furon Q-Valves were tested for reliability in hydrochloric acid (HCl) by an independent test lab¹. An accelerated life test was used to determine the B₁₀ life — the number of cycles at which 10% of the valves would be expected to fail.

Accelerated Life Test Method

Eight 1/4" Q-Valves were assembled in a manifold allowing two parallel flow paths through each set of 4 valves. Each set was cycled 3 seconds open and 3 seconds closed at room temperature with an actuator pressure of 80 psig. One set was opened as the other set was closed to maintain a constant flow of acid through the system at 74-80 psig. Flow was provided by a double diaphragm pump. Valves were inspected every workday for leaks.

The accelerated life test was performed on two sets of eight valves in 37% cleanroom grade HCl. The acid was replaced halfway through the test to ensure that full chemical strength was maintained.

Valves were tested for cracking pressure and port-to-port leakage throughout the test. Cracking pressure was measured by applying increasing air pressure to the closed valve and measuring the pressure at which the valve opened. Both inlet and outlet ports were tested. A valve failed if the cracking pressure was less than 110 psig, or 110 % of the 100 psig specification. Port-to-port integrity was measured by applying the rated pressure (100 psig) to a closed outlet port and monitoring the pressure downstream of the valve. Failure was indicated by a rise greater than 2.1 psi in 10 minutes, which is equivalent to a water leak rate of 0.05 ml H₂O/hour.

Results

No valves failed during the 2.1 million cycle accelerated life test in HCl. Statistical analysis of the results are shown in Table 1. Since no valves failed during the test, the Weibayes method was used to determine the B₁₀ life of the valves. Valves in both tests meet the acceptable B₁₀ life requirement of > 2.1 million cycles.

Summary

Eight Furon Q-Valves were tested for reliability and particle cleanliness following cycling. The valves were subjected to accelerated life tests in 37% HCl. The valves were cycled 2.1 million times with no observed leaks and no failures. Statistical analysis of the data show that the B₁₀ life of the valves was ≥ 2.1 million cycles.

Table 1: Results of accelerated life test

	37% HCl
Cycles Completed	2,100,00
Failures	0
B ₁₀ life	≥ 2.1 million cycles*
Weibull mean time to fail	≥ 2.5 million cycles*

*Since no failures occurred, these values are lower bound estimates.

Accelerated Life Test Schematic

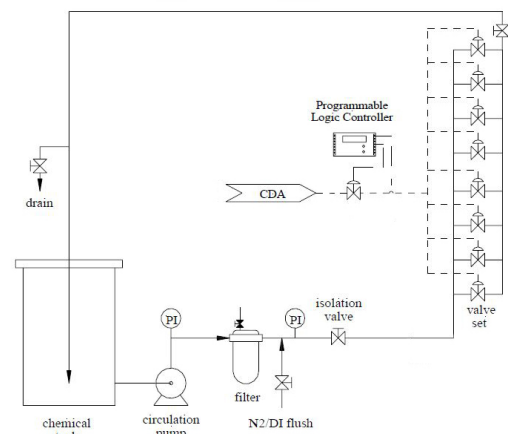

References

R. B. Abernethy, The New Weibull Handbook,
R. B. Abernethy, 2000.

¹CT Associates, Inc., 10777 Hampshire Ave. S., Bloomington, MN 55438.

The data provided here were obtained under defined test conditions. The tests were designed to mimic use or worst case conditions. However, Saint-Gobain Performance Plastics makes no specific claims about the performance of the components in other chemicals or systems.