

Statement of Performance

Furon[®] HPVM Accelerated Life Testing in Cabot Semi-Sperse[®] 12 Slurry

An accelerated life test was conducted on Furon HPVM valves, which were subjected to 1,500,000 cycles in Cabot Semi-Sperse 12 slurry, by an independent test lab¹ using the protocol of a major US OEM manufacturer.

Accelerated Life Test Method

Eight HPVM valves were assembled in two sets to allow two parallel flow paths through each set of 4 valves. Each set was cycled 2.5 seconds open and 2.5 seconds closed at room temperature with an actuator pressure of 70 psig. One set was opened as the other set was closed to maintain a constant flow of liquid through the system. The slurry Particle Sizing Distribution (PSD) was monitored on a daily bases. The slurry was considered to be in specification if the mean particle diameter was between 130 nm and 180 nm and if 99% of the distribution was inferior to 500 nm. As a result the slurry was replaced approximately every 150,000 cycles.

Prior to each valve integrity test, the valve manifold was extensively flushed with deionized water and drained completely. The turbidity of the rinse water was used to determine whether the test system had been flushed sufficiently. Following flushing, each valve was removed from the manifold and actuated to ensure that it was operating properly.

The liquid leak rate across the seat of the valve was measured at differential pressures across the valve seat of 35 PSI and 65 PSI. Measurements were made by pressurizing the valve outlet relative to the valve inlet. The valve leak rate across the seat was determined by calculating the derivative of the weight versus time curve at 3 minutes.

Results

Valve ID number	As-Received		298,000 cycles		605,000 cycles		901,500 cycles	
	Equivalent Total Liquid Leak Rate (ml/hr)	Equivalent Liquid Leak Rate Across Seat (ml/hr)	Liquid Leak Rate Across Seat at 35 psig (ml/hr)	Liquid Leak Rate Across Seat at 65 psig (ml/hr)	Liquid Leak Rate Across Seat at 35 psig (ml/hr)	Liquid Leak Rate Across Seat at 65 psig (ml/hr)	Liquid Leak Rate Across Seat at 35 psig (ml/hr)	Liquid Leak Rate Across Seat at 65 psig (ml/hr)
4274067	0.02	0.02	0.02	0.17	0.79	4.50	5.67	10.38
4274068	0.02	0.02	0.02	0.03	0.02	0.02	0.02	3.00
4274069	0.02	0.02	0.04	1.65	0.02	0.02	0.02	0.02
4274070	0.02	0.02	0.02	1.17	0.02	0.30	0.10	3.15
4274071	0.02	0.02	0.02	9.21	0.02	0.03	0.82	0.46
4274072	0.02	0.02	0.02	0.04	0.79	0.84	0.08	0.61
4274073	0.02	0.02	0.02	0.04	0.02	0.02	0.04	1.52
4274074	0.02	0.02	0.04	0.27	0.48	8.95	0.02	0.96
Geo Mean	0.02	0.02	0.02	0.27	0.07	0.20	0.10	0.97

Valve ID number	1,212,500 cycles		1,520,500 cycles	
	Liquid Leak Rate Across Seat at 35 psig (ml/hr)	Liquid Leak Rate Across Seat at 65 psig (ml/hr)	Liquid Leak Rate Across Seat at 35 psig (ml/hr)	Liquid Leak Rate Across Seat at 65 psig (ml/hr)
4274067	33.54	58.97	0.02	1.05
4274068	0.03	0.13	0.02	0.02
4274069	0.93	2.48	0.03	0.04
4274070	0.02	0.13	0.02	0.02
4274071	2.86	13.31	0.02	0.59
4274072	0.64	2.11	0.42	0.99
4274073	1.81	9.65	0.02	0.02
4274074	9.88	30.56	0.14	1.06
Geo Mean	0.92	3.44	0.04	0.15

Figure 1 - Accelerated Life Test Schematic

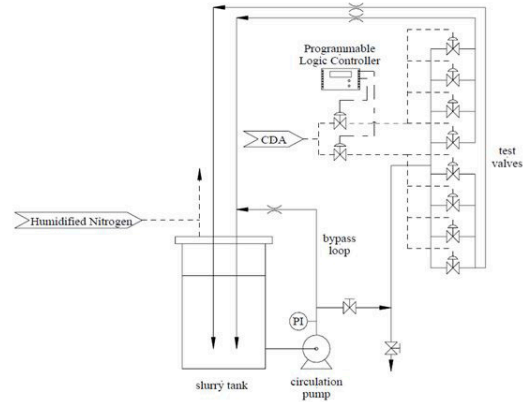

Summary

Eight Furon HPVM valves were successfully exposed to 1,500,000 cycles in Cabot Semi-Sperse 12 slurry accelerated life cycle test without suffering any major performance loss and all tested parameters completed at fixed intervals were acceptable.

References

¹CT Associates, Inc., 1721 Shady Oak Road, Eden Prairie, MN 55344.

The data provided here were obtained under defined test conditions. The tests were designed to mimic use or worst case conditions. However, Saint-Gobain Performance Plastics makes no specific claims about the performance of the components in other chemicals or systems.

