



## FURON<sup>®</sup> RDVM & SMDVM VALVE

### SELF-MANIFOLDING DISTRIBUTION VALVE

Furon high-purity, PFA injection molded RDVM and SMDVM Rolling Diaphragm Valves offer a revolutionary new concept in high flow fluid handling systems. RDVM and SMDVM Valves, combined with the Furon Universal fitting system, allow system integrators the unique ability to quickly configure and assemble custom valve manifolds utilizing standard off-the-shelf valves and fittings.

The RDVM 2-way valve can be utilized as a stand-alone valve featuring a small footprint and high flow rate or can be used in conjunction with the SMDVM.

The SMDVM 2-way valve offers an additional 3rd or 4th port that supports self-manifolding of multiple valves.

#### APPLICATIONS

- Bulk Chemical Delivery Systems and Chemical Distribution Systems in Semiconductor fabs
- Valve boxes
- Chemical processing applications
- Ultra-pure deionized water applications
- Suitable for use in abrasive slurry

#### FEATURES AND BENEFITS

- High flow factor, Cv 15
- 100% PFA HP and Virgin PTFE wetted flow path
- Patented rolling diaphragm technology
- Modular design allows for easy maintenance
- Visual position indicator standard on manual and pneumatic versions
- Quick-release, non-metallic 8-position mounting base
- Non-gender, close coupled space saver fittings
- 2-Way Valve available in 3-port and 4-port configurations
- RDVM valve designs have been tested for more than 1 million cycles

# Furon® RDVM & SMDVM Valve Pneumatic & Manual

## SPECIFICATIONS

Description	Actuation	Number of Ports	End Connection Type	Orifice		End Connection Size
				in	mm	
RDVM2-16NC	Pneumatic Normally Closed	2	Universal	1	25.4	Select from Table Below
RDVM2-16NO	Pneumatic Normally Open					
RDVM2-16MT	Multi-Turn Manual					
SMDVM3-16NC	Pneumatic Normally Closed	3				
SMDVM3-16NO	Pneumatic Normally Open					
SMDVM3-16MT	Multi-Turn Manual					
SMDVM4-16NC	Pneumatic Normally Closed	4				
SMDVM4-16NO	Pneumatic Normally Open					
SMDVM4-16MT	Multi-Turn Manual					

## FURON UNIVERSAL FITTINGS (one required for each end connection)

Description	End Connection Type	End Connection Size		Hex Size		Ratchet
		in	mm	in	mm	
UTG16F8N-1	FlareGrip® II	1/2	12.7	1-1/4	31.75	YES
UTG12F12N-1	FlareGrip® II	3/4	19.05			
UTG16F16N-1	FlareGrip® II	1	25.4			
UTG16FF8N-1	FlareGrip® II Female	1/2	12.7			
UTG16FF12N-1	FlareGrip® II Female	3/4	19.05			
UTG16FF16N-1	FlareGrip® II Female	1	25.4			
MTG16F8N-1	FlareGrip® II	1/2	12.7	1-1/2	38.1	NO
MTG16F12N-1	FlareGrip® II	3/4	19.05			
MTG16F16N-1	FlareGrip® II	1	25.4			
MTG16FF8N-1	FlareGrip® II Female	1/2	12.7			
MTG16FF12N-1	FlareGrip® II Female	3/4	19.05			
MTG16FF16-1	FlareGrip® II Female	1	25.4			

## UTG FITTINGS FEATURES

- 1.25" Hex (31.75 mm)
- Ratchet on End Connection Fittings (Flare)
- No O-Ring
- Short Tongue & Groove Interface



## MTG FITTINGS FEATURES

- 1.5" Hex (38.1 mm)
- No Ratchet on End Connection Fittings (Flare)
- Chemraz® O-Ring
- Long Tongue & Groove Interface



## OPTIONS

- Available with or without purge ports (add -001 to indicate purge port or -002 to indicate no purge port)
- Fiber optic position indicator on pneumatic valves
- Other end connection types available.
  - Nippon Pillar Super 300
  - Others not listed

Please contact us for further details

## RDVM / SMDVM PORT LOCATIONS (UTG VS. MTG FITTINGS)

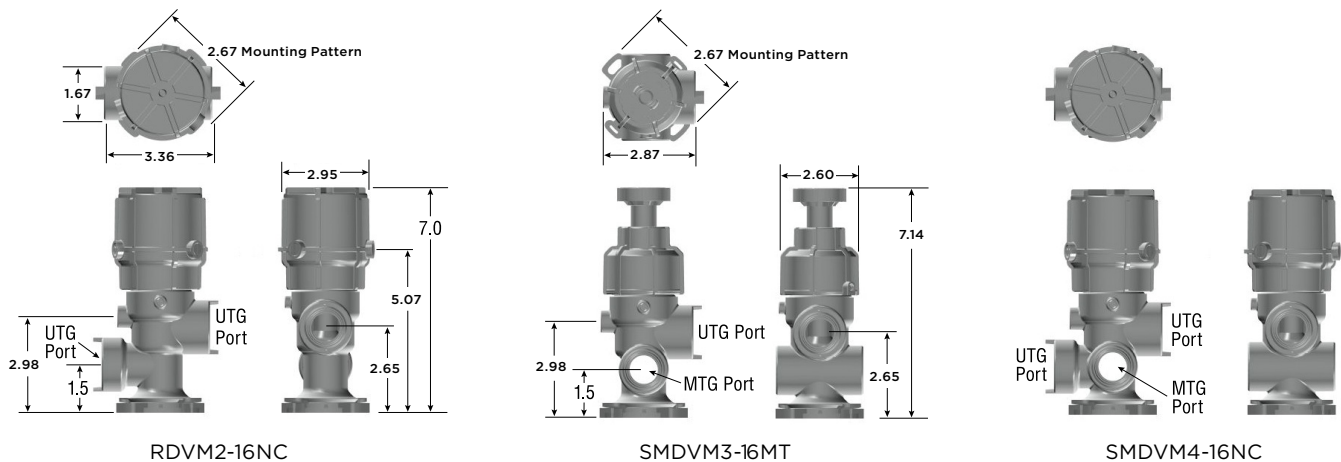

# Furon® RDVM & SMDVM Valve Pneumatic & Manual

## FURON COUPLERS & PLUGS (one required per valve stick)

Description	Type	End Connection Type	End Connection Size		Hex Size		Ratchet
			in	mm	in	mm	
UTG16SU	Coupler	Universal	1	25.4	1-1/4	31.8	YES
UTG16MTG16SU	Coupler						
MTG16SU	Coupler						NO
MTG Plug	Plug						

## COUPLER/PLUGS



### UTG16SU

Used to connect multiple valves on a single stick (UTG port to UTG Port connection).



### UTG16MTG16SU

Used to connect a UTG port on one valve to a MTG port on another valve.



### MTG16SU

Used to connect MTG ports on two valves. Commonly used to add a valve stick to a manifold assembly.

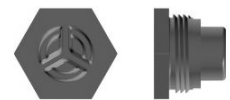

### MTG Plug

Used to plug the MTG port on the last valve stick in the manifold.

## TECHNICAL SPECIFICATIONS

Operating Pressure	100 psig (6.9 bar)
Back Pressure	100 psig (6.9 bar)
Flow	Up to 15
Max. Operating Temperature	Ambient: 122°F (50°C) Media: 212°F (100°C)
Actuator Pressure (Pneumatic Version)	60-90 psig (4.1-6.2 bar)
Body	PFA
Diaphragm	Modified PTFE
Actuator Housing	Polypropylene

Tested with HCl for more than 450 thousand cycles

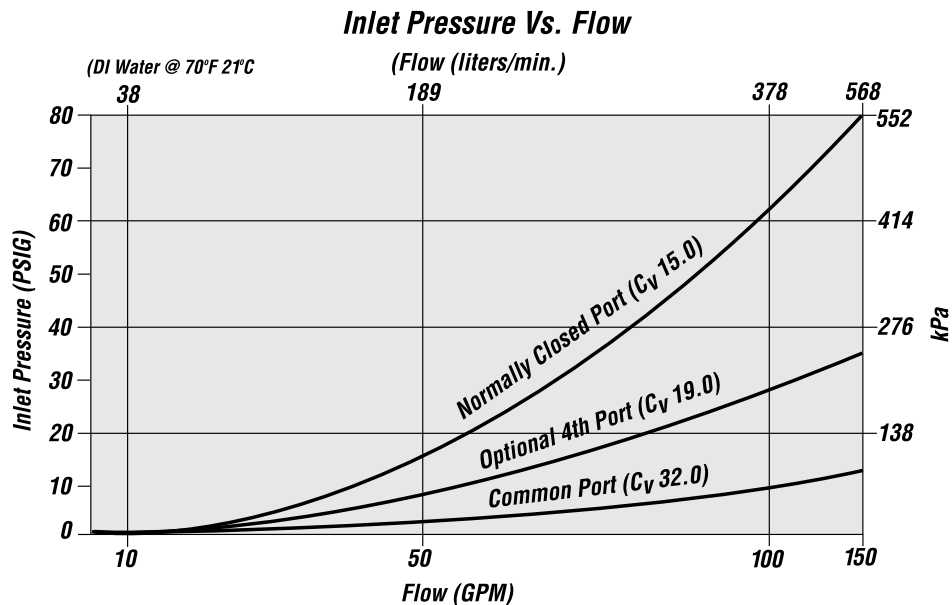

# Furon® RDVM & SMDVM Valve Pneumatic & Manual

## ASSEMBLY EXAMPLE

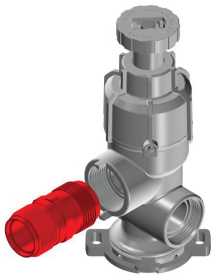

### Step 1

Start with a Manual SMDVM PN 1109180-002 (No Purge port)  
Thread UTG16SU Coupler, PN 1109225-003 into SMDVM NO (UTG) port until snug, approximately 4.5 - 5 turns, this will allow "clocking" of valves.

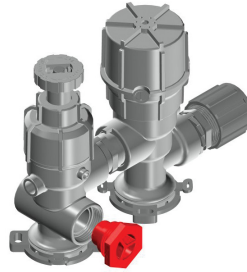

### Step 4

Use MTG Plug PN: 1109616 in the MTG port you would like capped off. Thread the fitting into the valve body until the tongue and groove engages... then turn another 1/2 to full turn.

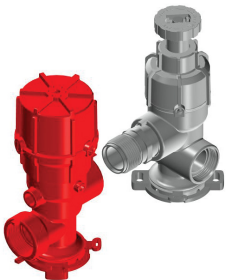

### Step 2

2nd Valve: RDVM PN 1109177-002 (No Purge port)  
Turn RDVM approximately 5 turns until the tongue and groove interface makes contact...then continue turning until valves are aligned.  
There should be 1/2 turn to clock valves (Clockwise)

1. Port to port dim.  
0.93"-0.95" (23.62-24.13 mm)

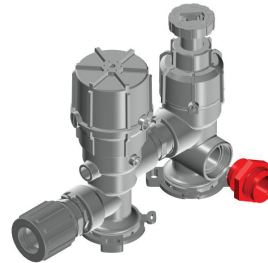

### Step 5

Thread MTG16SU Coupler, PN 1107019 into SMDVM Common port until snug, approximately 1 - 1.5 turns, this will allow proper "clocking" of valves.

The MTG fittings uses a similar tongue and groove design to the Universal fitting (UTG) but they are not interchangeable. The SMDVM common port uses a Chemraz® O-ring as a secondary containment.

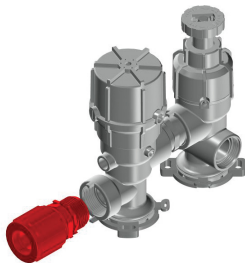

### Step 3

This configuration uses PN: 1110681-1  
a 1" Fine Thread Flare by 1" UTG.  
Thread the Universal Fitting clockwise until the ratchet engages to the valve body.

Notes:  
1. 18 clicks past ratchet engagement to seal the fitting.

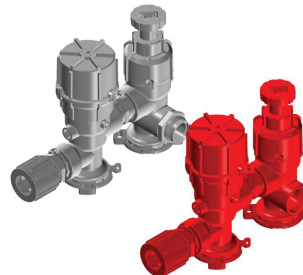

### Step 6

Our Manifold configuration is made up of two identical valve sticks consisting of a manual and pneumatic valve. Thread the MTG16SU Coupler into the mating SMDVM Common port. Turn the second valve stick approximately 2.5 turns until the tongue and groove interface makes contact... then continue turning until valves are aligned. There should be 1/2 turn to clock valves (Clockwise)

1. Port to port dim.  
0.42"- 0.44" (10.66 -11.17 mm)



## Saint-Gobain Performance Plastics

**China** (+8621) 5472 1568  
Sales.PPLCN@saint-gobain.com

**Europe** (+33) 3 85 20 27 00  
quotes-clm@saint-gobain.com

**India** (+91) 80 46978888  
pplindia.hc@saint-gobain.com

**Japan** (+81) 3 6256 9703  
ls-japan@saint-gobain.com

**Korea** (+82) 2 6098 0180  
LS-Korea@saint-gobain.com

**Southeast Asia** (+66) 38 667 800  
cs.sgplsea@saint-gobain.com

**Taiwan** (+886) 2 2503 4201  
Taiwan.ppl@saint-gobain.com

**United States** (+1) 800-833-5661  
gardengrovequoteteam@saint-gobain.com

**All Other Regions**  
www.furon.com

**NOTE:** This document is intended to provide information about the product to enable you to consider whether generally the Product meets your application need and is not intended to provide product specification. This document should not be considered a Product warranty or guaranty. To the extent this document mentions any tests done by Saint-Gobain, such tests are done under controlled laboratory circumstances and hence other factors in your use and application may impact such values. Saint-Gobain strongly recommends that you conduct practical tests simulating the conditions of your application to ensure that the product meets your requirements for your specific application

Furon® and FlareGrip® are registered trademarks of Saint-Gobain Performance Plastics. Nippon Pillar Super 300® is a registered trademark of Nippon Pillar Packing Co.

**WARRANTY:** Saint-Gobain warrants that the Product will meet specifications at the time of delivery and honor such warranty claims for a period of 18 months after delivery. In the event that you are a distributor purchasing Saint-Gobain Product, any change to specification while in your control as a result of storage conditions or otherwise may cause the above warranty to be voided. THIS IS THE EXCLUSIVE WARRANTY AND IS EXPRESSLY IN LIEU OF ANY AND ALL OTHER OBLIGATIONS, GUARANTEES, WARRANTIES AND REPRESENTATIONS. SAINT-GOBAIN DISCLAIMS ALL IMPLIED WARRANTIES OF MERCHANTABILITY AND FITNESS FOR A PARTICULAR PURPOSE.