



## FURON<sup>®</sup> HGVM VALVE

2-WAY MANUAL  
2" ORIFICE

Furon HGVM Manual Valves offer a reliable means of handling large volumes of aggressive or ultra-pure chemistries. Engineered from virgin PTFE, injection molded PFA and other engineered thermoplastics, Furon HGVM valves offer the highest Cv flow factors of any fluoropolymer valve of its size. Our patented PTFE rolling diaphragm is ideal for use in high back pressure conditions, which are commonly found in Bulk Chemical Delivery Systems. In-line fluid ports and a fully swept internal flow path support maximum flow efficiency. The manually-actuated version features a large, ergonomically designed adjustment knob for ease of operation while wearing cleanroom gloves. They also feature our time-proven O-ring Free Union end connections, simplifying installation and eliminating the potential for elastomeric contamination and offer extra protection against chemical leakage, which provides a secondary sealing surface and locking design feature.

### APPLICATIONS

Furon HGVM Valves are ideal for use in the semiconductor industry, or other applications requiring high purity and/or superior chemical resistance.

- Bulk Chemical Delivery Systems in the Semiconductor Industry
- Suitable for use in abrasive slurry
- Transfer of large volumes of aggressive, abrasive, and/or ultra-high purity chemistries.

### FEATURES AND BENEFITS

- 52 Cv flow factor
- All virgin PTFE and PFA wetted flow path
- Fully swept internal flow path
- Patented rolling diaphragm
- Visual position indication facilitates end user safety
- In-line ports support maximum flow efficiency and ease of installation
- No "O-Ring" double seal union eliminates dead space and elastomeric contamination with locking design features for improved protection
- High back pressure capability ensures safety and high performance

# Furon® HGVM Valve Manual

## SPECIFICATIONS

Description	Actuation	End Connection Type	Orifice		End Connection Size	
			in	mm	in	mm
HGVM2-73232-MT	Multi-Turn	FuseBond™	2	50.8	2*	DN 50*
HGVM2-73224-MT	Multi-Turn	FuseBond™			1-1/2*	DN 40*

\*Nominal by Schedule 40 Pipe

## TECHNICAL SPECIFICATIONS

Operating Pressure	80 PSIG (5.5 bar)
Back Pressure	80 PSIG (5.5 bar)
Flow	Cv 52
Operating Temperature	Ambient: 122°F (50°C) Media: 212°F (100°C)
Body	PFA
Diaphragm	Modified PTFE
Actuator Housing and Knob	Polypropylene

Tested with HF for more than 300 thousand cycles in pneumatic HGVM Valve

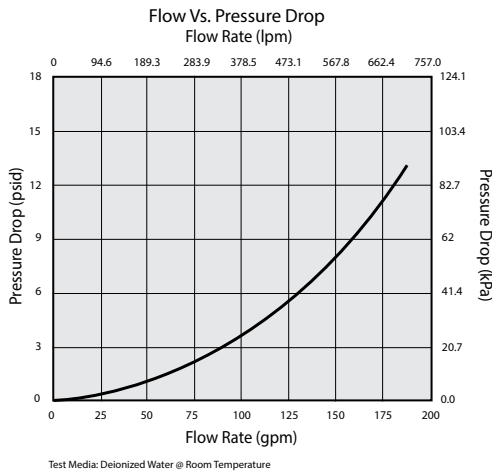

## OPTIONS

Other end connection types available:

- Nippon Pillar Super 300®
- Others not listed

[Please consult our engineers](#) for details.

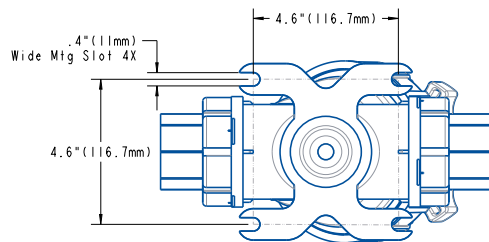
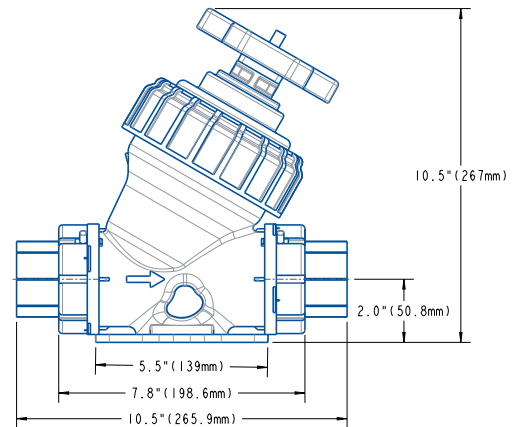

## Saint-Gobain Performance Plastics

**China** (+86) 400 888 0198  
sales.PPSCN@saint-gobain.com

**Europe** (+33) 3 85 20 27 00  
quotes-clm@saint-gobain.com

**India** (+91) 76208 22999  
pplindia.hc@saint-gobain.com

**Japan** (+81) 3 6256 9703  
ls-japan@saint-gobain.com

**Korea** (+82) 2 6098 0180  
LS-Korea@saint-gobain.com

**Southeast Asia** (+66) 38 667 800  
cs.sgpplsea@saint-gobain.com

**Taiwan** (+886) 2 2503 4201  
Taiwan.ppl@saint-gobain.com

**United States** (+1) 800-833-5661  
gardengrovequoteteam@saint-gobain.com

**All Other Regions**  
www.furon.com



**NOTE:** This document is intended to provide information about the product to enable you to consider whether generally the Product meets your application need and is not intended to provide product specification. This document should not be considered a Product warranty or guaranty. To the extent this document mentions any tests done by Saint-Gobain, such tests are done under controlled laboratory circumstances and hence other factors in your use and application may impact such values. Saint-Gobain strongly recommends that you conduct practical tests simulating the conditions of your application to ensure that the product meets your requirements for your specific application

Furon®, FlareGrip® and FuseBond™ are registered trademarks of Saint-Gobain Performance Plastics. Nippon Pillar Super 300® is a registered trademark of Nippon Pillar Packing Co.

**WARRANTY:** Saint-Gobain warranties that the Product will meet specifications at the time of delivery and honor such warranty claims for a period of 18 months after delivery. In the event that you are a distributor purchasing Saint-Gobain Product, any change to specification while in your control as a result of storage conditions or otherwise may cause the above warranty to be voided. THIS IS THE EXCLUSIVE WARRANTY AND IS EXPRESSLY IN LIEU OF ANY AND ALL OTHER OBLIGATIONS, GUARANTEES, WARRANTIES AND REPRESENTATIONS. SAINT-GOBAIN DISCLAIMS ALL IMPLIED WARRANTIES OF MERCHANTABILITY AND FITNESS FOR A PARTICULAR PURPOSE.