

# CASE STUDY

Combined Pneumatically Actuated and Manual Toggle Valve Improves Maintenance Operations

# FURON<sup>®</sup>

Pure Performance

ASK AN ENGINEER

## The Challenge

Routine preventive maintenance for semiconductor fabrication systems includes flushing any residual liquids from each component installed on the process line thereby purging the entire system.

To accomplish this, an operator must turn off every pneumatically actuated valve from a centralized control panel that is often in a remote location. This common practice, however, has the potential to create a serious safety issue as it removes maintenance staff from the operating area, preventing them from ensuring that all chemicals were properly flushed.

## The Saint-Gobain Collaborative Service Solution

To best understand how Saint-Gobain could eliminate this safety pain point for our customer, our team traveled to the customer's fabrication site to accurately assess the process line and determine the proper design solution by documenting the types and sizes of each system valve. As a result of the visit, the following requirements were identified:

- Adding manually actuated valves to the fab's existing pneumatic operation
- Using industry-trusted valves with a reputation for compatibility, reliability and a wide range of sizes/flow coefficient (Cv)
- Restricting manual operations to a specific operator if/when wanted

To meet these needs, our design team developed a new valve that combines a pneumatically actuated valve with manual toggle functionality. This patent-pending valve solution can be installed on various Saint-Gobain high purity [manifold valves](#), such as [Furon<sup>®</sup> HPVM](#), [Furon<sup>®</sup> CDV](#) and more.

Additionally, the toggle function can be removed and added back as needed to limit access to a particular maintenance staff member.

## Customer Experience

To further substantiate the solution's form, fit and function, Saint-Gobain's dedicated Prototype Development Center utilized manufacturing drawings to create samples. And within a few days, prototypes were shipped to the fabricator for internal validation testing.

As a result of the collaboration between Saint-Gobain and the customer, not only is the operation's maintenance staff able to flush its process line manually at the operation location and without any disruptive impact on the valve's normal functionality but the customer has reported improved maintenance efficiency and safety thanks to the utilization of this new, unique solution.

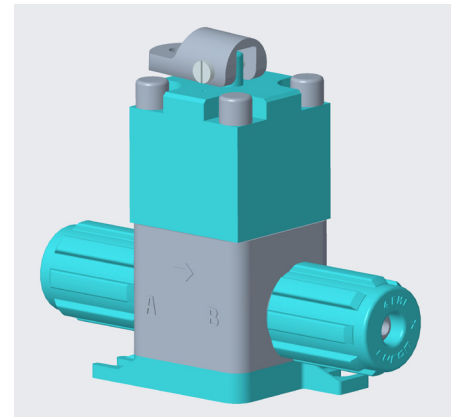

A rendering of Saint-Gobain's new valve solution, which combines pneumatic actuation and manual toggle functionality, as applied to a Furon HPVM valve.

This patent pending valve design was developed to improve routine maintenance safety. Because the toggle function can be removed and added back as needed, it is able to limit access to a specific maintenance staff member.