



FURON[®] **MDP 1000 PUMP** MINI DOSING PUMP 0-10 ML

Furon MDP 1000 pumps provide an efficient solution for accurately dispensing small amounts of liquids. Designed with a 100% fluoropolymer wetted flow path, Furon mini dispensing pumps are suitable for use with highly corrosive media, or in applications where ultra-high purity media is a must.

Furon MDP 1000 pumps are pneumatically driven. When pilot air is applied to the actuator, the pump dispenses the desired volume. Manual adjustment knobs allow for easy setting of dispense volume (shot size) and dispense speed. Patented PTFE rolling diaphragm technology assures high dispense accuracy and repeatability.

Compact and efficient design makes Furon mini dispensing pumps an ideal solution for dosing of liquids in Semiconductor wet processes, accurate dispensing of liquids into containers or vials (filling line equipment), industrial chemical processing, or any other application requiring accurate dispensing of small doses of liquid.

APPLICATIONS

- Dosing of liquids in Semiconductor wet processes
- Blending of abrasive slurries in CMP systems
- Spiking chemicals into DI water streams
- Dispensing of liquids into containers (Fill and Finish)
- Injection of colors, flavors, or other chemicals in a manufacturing process
- Laboratory equipment

FEATURES AND BENEFITS

- Efficiently dispenses small amounts of liquid (up to 10 mL)
- Ideal alternative to peristaltic pumps
- Virgin PTFE and PFA wetted flow path suitable for ultrapure applications
- Suitable for use with corrosive and aggressive media
- Dispense accuracy and repeatability $\pm 1\%$ *
- Fine adjustable dispense volume and speed
- Compact design

*When the dose is set and the repeatability is 1% of the set point

Furon® MDP 1000 Pump

SPECIFICATIONS

Description	Max Dispense Volume	End Connection Type	Orifice		Port Size	
			in	mm	in	mm
MDP1000	10 mL	FlareGrip® II	1/4	6.35	1/4	6.35

OPTIONS

Alternate end connections

- Other sizes of flare ends
- Nippon Pillar Super 300®
- Grab Seal™
- Others not listed

[Please contact us](#) for more details

TECHNICAL SPECIFICATIONS

Operating Temperature	Ambient: 32°F to 120°F (0°C to 50°C) Media: 41°F to 180°F (5°C to 82°C)
Single Dispense Capacity (shot size)	0 - 10 mL
Dispense Speed	Full dispense in 1.0 sec to 3.0 sec, Adjustable 3.3 to 10.0 mL/sec
Dispense Accuracy	±1%
Dispense Repeatability	±1%
Actuation Air Pressure	50 - 70 PSIG (3.4 - 4.8 bar)
Maximum Discharge Pressure	55 PSIG (3.8 bar) at 70 PSIG (4.8 bar) air actuation

* [Please consult factory](#) for higher viscosity >>

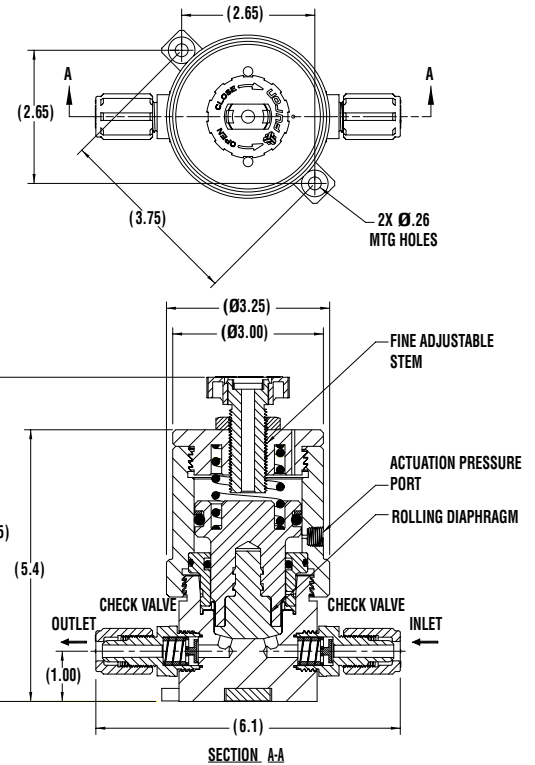

Saint-Gobain Performance Plastics

China (+86) 400 888 0198
sales.PPSCN@saint-gobain.com

Europe (+33) 3 85 20 27 00
quotes-clm@saint-gobain.com

India (+91) 76208 22999
pplindia.hc@saint-gobain.com

Japan (+81) 3 6256 9703
ls-japan@saint-gobain.com

Korea (+82) 2 6098 0180
LS-Korea@saint-gobain.com

Southeast Asia (+66) 38 667 800
cs.sgplsea@saint-gobain.com

Taiwan (+886) 2 2503 4201
Taiwan.ppl@saint-gobain.com

United States (+1) 800-833-5661
gardengrove@team@saint-gobain.com

All Other Regions
www.furon.com

NOTE: This document is intended to provide information about the product to enable you to consider whether generally the Product meets your application need and is not intended to provide product specification. This document should not be considered a Product warranty or guaranty. To the extent this document mentions any tests done by Saint-Gobain, such tests are done under controlled laboratory circumstances and hence other factors in your use and application may impact such values. Saint-Gobain strongly recommends that you conduct practical tests simulating the conditions of your application to ensure that the product meets your requirements for your specific application

Furon®, FlareGrip® and Grab Seal™ are registered trademarks of Saint-Gobain Performance Plastics. Nippon Pillar Super 300® is a registered trademark of Nippon Pillar Packing Co.

WARRANTY: Saint-Gobain warrants that the Product will meet specifications at the time of delivery and honor such warranty claims for a period of 18 months after delivery. In the event that you are a distributor purchasing Saint-Gobain Product, any change to specification while in your control as a result of storage conditions or otherwise may cause the above warranty to be voided. THIS IS THE EXCLUSIVE WARRANTY AND IS EXPRESSLY IN LIEU OF ANY AND ALL OTHER OBLIGATIONS, GUARANTEES, WARRANTIES AND REPRESENTATIONS. SAINT-GOBAIN DISCLAIMS ALL IMPLIED WARRANTIES OF MERCHANTABILITY AND FITNESS FOR A PARTICULAR PURPOSE.