

FURON[®] A2 PUMP

AIR OPERATED
BELLOWS PUMP
15 LPM/4 GPM -
60 LPM/16 GPM

Furon A2 Pumps are pneumatically-operated, driven by two reciprocating PTFE bellows. Their oscillation frequency is much lower than an equivalent diaphragm pump, resulting in an extended life and reduced cost of ownership.

All Furon A2 Pump wetted components are manufactured from high-purity PTFE and PFA, making them suitable for handling the most aggressive concentrated chemicals. All other (non-wetted) components are manufactured from advanced engineering thermoplastics, such as ETFE and PEEK to ensure no possibility of ionic contamination, even in the event of a bellows failure. Furon A2 Pumps are 100% elastomer free, using our highly reliable, No O-Ring sealing technology throughout. This substantially reduces the chance of contamination due to a failed O-Ring as well as reduces maintenance costs.

Our pumps are self-priming, providing an easy installation and setup. In addition, the Furon A2 Pumps feature our innovative shuttle valve fixation technology, allowing us to provide three different driving systems to adapt our pumps to the customers' requirements.

APPLICATIONS

- Transfer of ultrapure acids and solvents used in the semiconductor industry
- Transfer of abrasive slurries
- Recirculation, dispensing, and filtration with controlled flow rates and volumes
- Bulk chemical delivery
- Laboratory equipment

FEATURES AND BENEFITS

- No metal parts
- 100% high purity PFA and PTFE wetted flow path
- 100% elastomer free
- Worldwide service center for preventive maintenance
- Unique recirculating pilot air concept to improve system uptime
- Stall-proof twin shuttle option available
- Low pulsation level with the use of Furon A2 Dampener technology
- Furon A2 Pumps have been tested for more than 130 million cycles
- ATEX compliant: II 3 G/c IIC TX X

SPECIFICATIONS

Base Part Number	Media	Pump Size	End Connection Type	End Connection Size		Driving System		
				in	mm	Single Standard Driving Valve	TWIN Shuttle Valve Driving System	External Driving
A2CH1 F8	Chemical	1	FlareGrip® II	1/2	12.7	Nothing to add to the base Part Number	Add TWIN at the end of the base Part Number	Add EXT at the end of the base Part Number
A2CH1 T8			Tube End					
A2CH2 F12		2	FlareGrip® II	3/4	19.05			
A2CH2 T12			Tube End					
A2CH3 F16		3	FlareGrip® II	1	25.4			
A2CH3 T16			Tube End					
A2SY1 F8	Slurry	1	FlareGrip® II	1/2	12.7			
A2SY1 T8			Tube End					
A2SY2 F12		2	FlareGrip® II	3/4	19.05			
A2SY2 T12			Tube End					
A2SY3 F16		3	FlareGrip® II	1	25.4			
A2SY3 T16			Tube End					

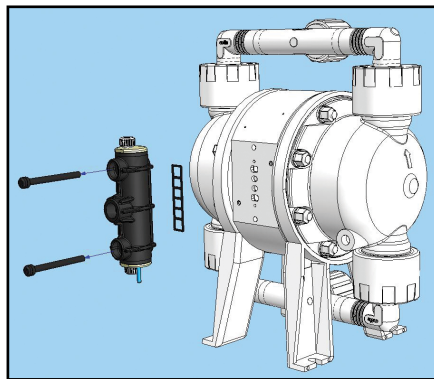

Single shuttle valve driving system

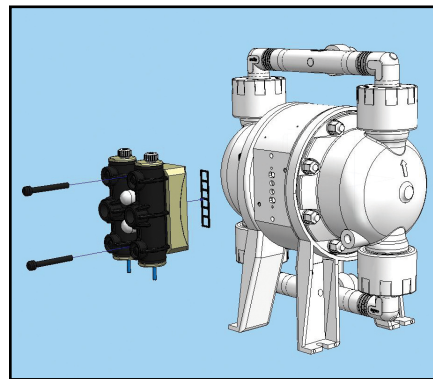

Twin shuttle valve driving system (Anti-stalling system)

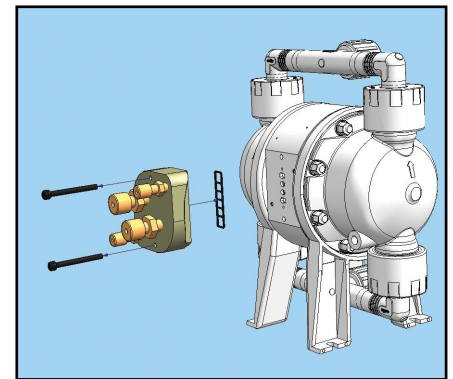

External driving (Allow a direct driving through a PLC system)

TECHNICAL SPECIFICATIONS

Pump Size	Maximum Flow Rate		Maximum Suction Head		Maximum Air Pressure*		Maximum Air Consumption		Maximum Back Pressure		Media Temperature Range**		Weight	
	gpm	lpm	ft	m	psi	bar	SCFM	m ³ /h	psi	bar	°F	°C	lbs	kg
1	4	15	10	3			4.5	7					5	2.26
2	8	30	12	3.5	87	6	6	9	80	5.5	30 - 185°F	0 - 85°C	9	4.08
3	16	60	14	4			9	14					16	7.25

* Please contact us for use with higher pressure

** Contact Us for higher-temperature version.

Max. Ambient Temperature: 140°F (60°C)

Tested for more than 130 millions cycles

OPTIONS

- Optic fiber for stroke counting (5 m (16.4 ft) standard)
 - PN = 9475
- Fiber optic converter
 - PN = 8319
- Metal free leak detection system
 - LD1 for size 1 & 2 pump
 - LD2 for size 3 pump
- Other manifold orientations than the standard horizontal/horizontal
- Various combinations of end connections available (Flare, tube, pipe, NPT).
Please consult our engineers for details.

FLOW RATE CURVES

PUMP SIZE 1

Air supply pressure (bar) and air consumption (NL/min) as a function of fluid flow rate (L/h) and discharge pressure (bar) Pump chemical A2 Size 1, Ø4x6 air pressure tube

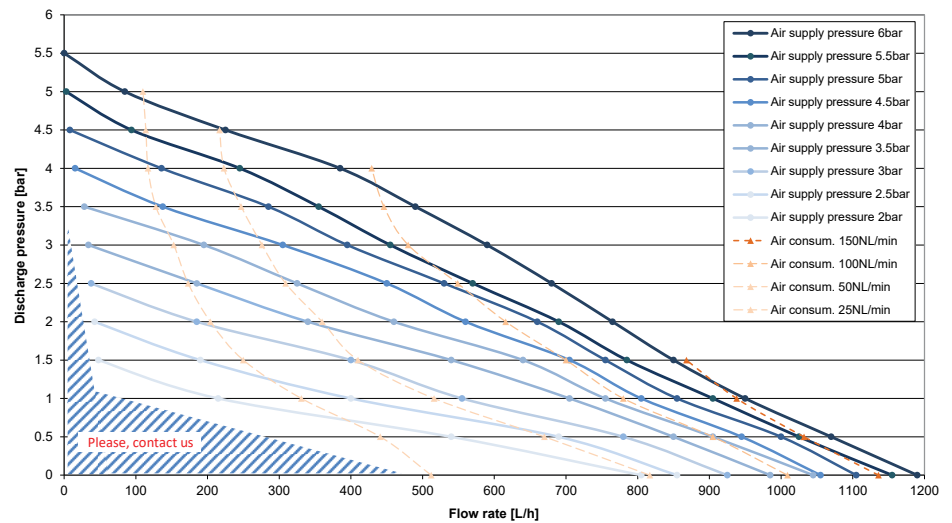

PUMP SIZE 2

Air supply pressure (bar) and air consumption (NL/min) as a function of fluid flow rate (L/h) and discharge pressure (bar) Pump chemical A2 Size 2, Ø6x8 air pressure tube

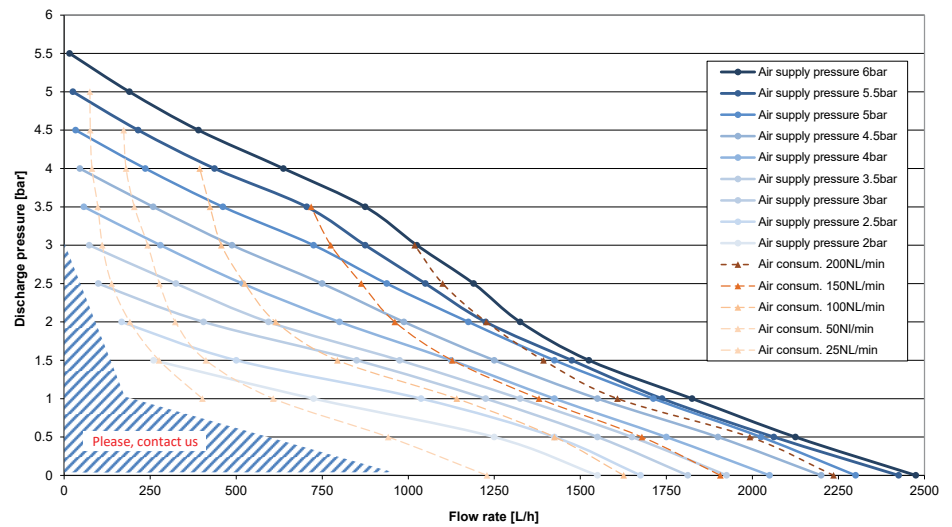

PUMP SIZE 3

Air supply pressure (bar) and air consumption (NL/min) as a function of fluid flow rate (L/h) and discharge pressure (bar) Pump chemical A2 Size 3, Ø8x10 air pressure tube

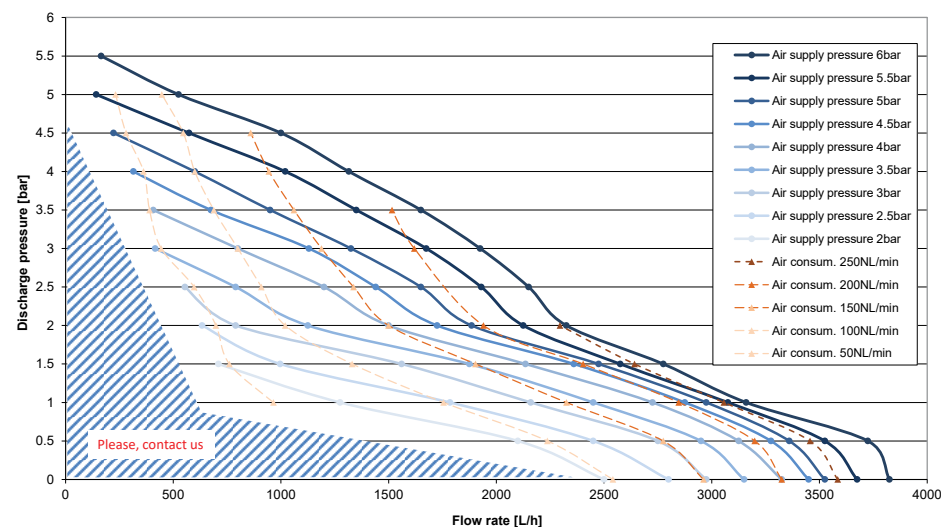

DIMENSIONS

	Pump Size 1					Pump Size 2					Pump Size 3							
	Control Side		Muffler Side		Air Connection	Control Side		Muffler Side		Air Connection	Control Side		Muffler Side		Air Connection			
	A	B	A	B		A	B	A	B									
in	mm	in	mm	in	type	in	mm	in	mm	in	type	in	mm	in	type			
Single Shuttle	2.8	71	-	-	3/8	NPT	3.25	82.5	-	-	3/8	NPT	4.72	120	-	-	3/8	NPT
Twin Shuttle	5.08	129	-	-	-	-	5.16	131	-	-	-	-	-	-	-	-	-	-
External Shuttle	4.87	123	-	-	See Note Below		5.21	132	-	-	See Note Below		5.84	148	-	-	See Note Below	
Muffler Only	-	-	2.28	58	-	-	-	-	2.74	69.5	-	-	-	-	5.43	138	-	-
Muffler & Leak Detection System	-	-	3.72	94.5	1/4	BSPP	-	-	3.72	95.5	1/4	BSPP	-	-	6.50	165	3/8	BSPP

Note: External Shuttle pumps' air connection sizes vary depending on pump model. See the corresponding [Operational Instruction Manuals](#) on our website [Document Center](#) page.

PUMP SIZE 1

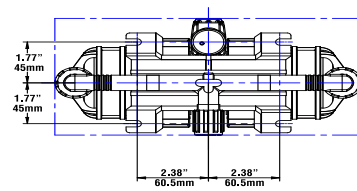
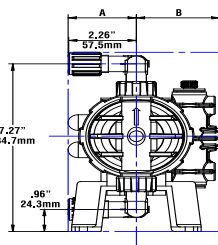
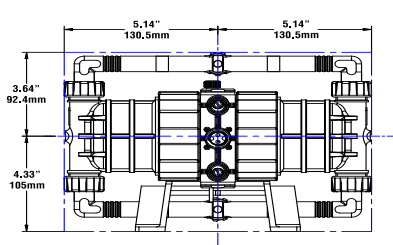

PUMP SIZE 2

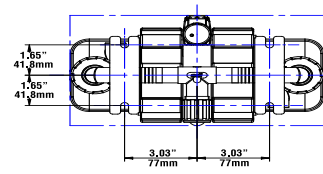
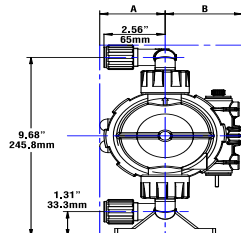
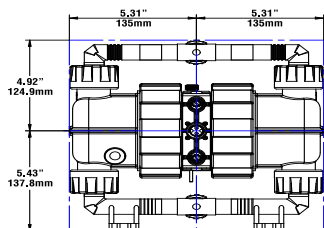

PUMP SIZE 3

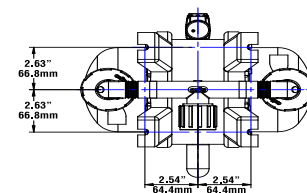
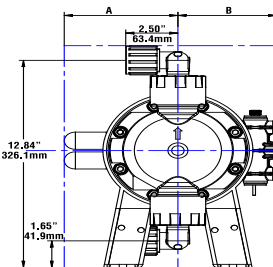
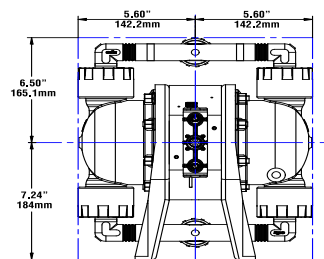

Saint-Gobain Performance Plastics

China (+8621) 5472 1568
Sales.PPLCN@saint-gobain.com
Europe (+33) 3 85 20 27 00
quotes-clm@saint-gobain.com
India (+91) 80 46978888
pplindia.hc@saint-gobain.com

Japan (+81) 3 6256 9703
ls-japan@saint-gobain.com
Korea (+82) 2 6098 0180
LS-Korea@saint-gobain.com
Southeast Asia (+66) 38 667 800
cs.sgplsea@saint-gobain.com

Taiwan (+886) 2 2503 4201
Taiwan.ppl@saint-gobain.com
United States (+1) 800-833-5661
gardengrovequoteteam@saint-gobain.com
All Other Regions
www.furon.com

NOTE: This document is intended to provide information about the product to enable you to consider whether generally the Product meets your application need and is not intended to provide product specification. This document should not be considered a Product warranty or guaranty. To the extent this document mentions any tests done by Saint-Gobain, such tests are done under controlled laboratory circumstances and hence other factors in your use and application may impact such values. Saint-Gobain strongly recommends that you conduct practical tests simulating the conditions of your application to ensure that the product meets your requirements for your specific application

Furon®, FlareGrip® and Grab Seal™ are registered trademarks of Saint-Gobain Performance Plastics. Nippon Pillar Super 300® is a registered trademark of Nippon Pillar Packing Co.

WARRANTY: Saint-Gobain warranties that the Product will meet specifications at the time of delivery and honor such warranty claims for a period of 18 months after delivery. In the event that you are a distributor purchasing Saint-Gobain Product, any change to specification while in your control as a result of storage conditions or otherwise may cause the above warranty to be voided. THIS IS THE EXCLUSIVE WARRANTY AND IS EXPRESSLY IN LIEU OF ANY AND ALL OTHER OBLIGATIONS, GUARANTEES, WARRANTIES AND REPRESENTATIONS. SAINT-GOBAIN DISCLAIMS ALL IMPLIED WARRANTIES OF MERCHANTABILITY AND FITNESS FOR A PARTICULAR PURPOSE.