

# Furon® Chempure™ 2" In-Line Valve

## Pneumatically Actuated 2-Way Valve



### Features/Benefits

- 52 C<sub>v</sub> flow factor
- All virgin PTFE-wetted flow path
- No exposed metallics
- Fully swept internal flow path
- Patent pending rolling diaphragm
- Visual position indication facilitates end-user safety
- In-line ports support maximum flow efficiency and ease of installation
- No "O" ring unions eliminate dead space and elastomeric contamination
- 3/8" fine thread flare fitting for purge/sampling port
- Leak detection port included
- Assembled and double-bagged in a class 100 cleanroom environment
- High flow capability reduces chemical supply time
- High purity design and build clean construction reduces possibility of process contamination
- Diaphragm technology enables long life and high pressure rating
- High back pressure capability ensures safety and high performance

### Operation

- Pneumatically actuated valve
- 80 PSIG rated/maximum operating pressure @ 22° C
- 80 PSIG rated/maximum back pressure @ 22° C
- Fluid temperature range from 5° C to 100° C

### Applications

- Designed for use in semiconductor chemical delivery, chemical processing, high purity, and corrosive chemical applications
- Ideal for applications that demand high purity coupled with high C<sub>v</sub> flow factor
- Highly recommended for central chemical supply systems

# Furon® ChemPure™ 2" In-Line Valve Pneumatically Actuated 2-Way Valve

## Ordering Information

Part Description	Availability	Inlet End Connection	Outlet End Connection	C <sub>v</sub> Flow Factor	Inlet Port Size	Outlet Port Size
HGV2-73232 NC	Stock	Fuse-Bond	Fuse-Bond	52	2"	2"
HGV2-73224 NC	Design On File	Fuse-Bond	Fuse-Bond	42	1.5"	1.5"

## Options

- Consult factory for other end connection configurations
- 3/8" Flare Grip® II purge/sampling port

## Specifications And Performance

- 80 PSIG maximum operating pressure
- 80 PSIG maximum back pressure
- Fluid temperature range from 5° C to 100° C
- Pilot air actuation pressure 60 PSIG minimum/80 PSIG maximum
- 52 C<sub>v</sub> flow factor with 2" end connections
- Weight: 11.3 lbs.

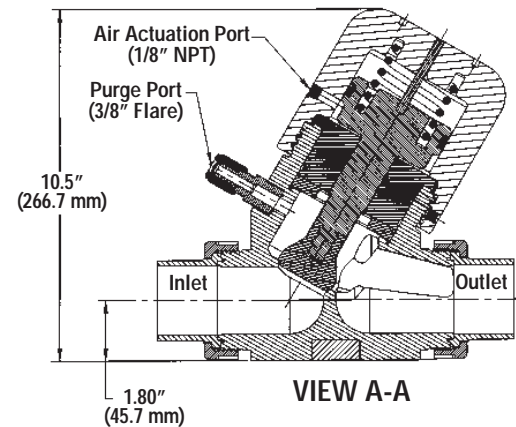
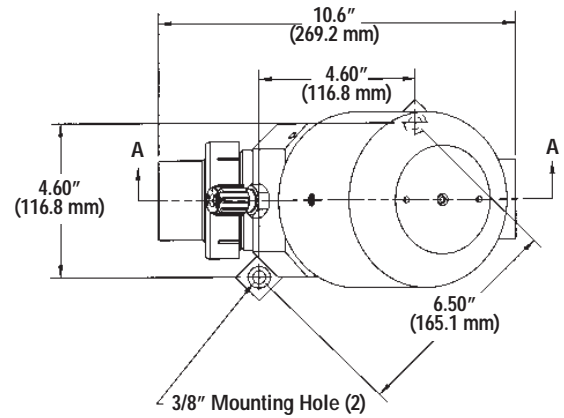

Maximum Inlet and Outlet Operating Pressure

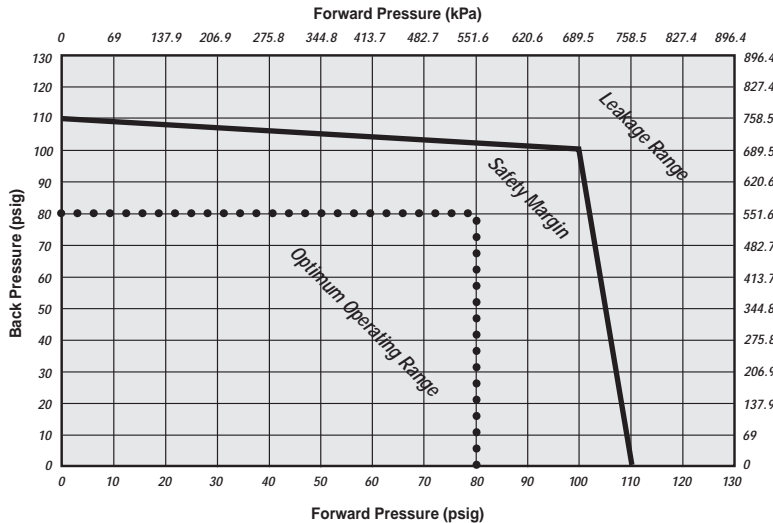

Flow Vs. Pressure Drop

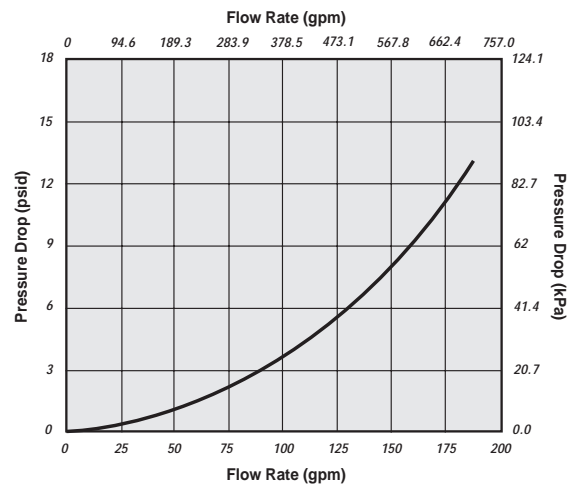

## Saint-Gobain Performance Plastics

7301 Orangewood Avenue  
Garden Grove, CA 92841-1411  
Tel: (714) 630-5818  
Fax: (714) 688-2614  
USA Toll Free: (800) 833-5661



Furon® is a registered trademark.  
Flare Grip® is a registered trademark.

**12-month Limited Warranty:** For a period of 12 months from the date of first sale, Saint-Gobain Performance Plastics Corporation warrants this product to be free from defects in manufacturing. This company's only obligation will be to provide replacement product for any material proven to have such a defect, or at SGPPL's option, to refund the purchase price thereof. User assumes all other risks, if any including the risk of injury, loss or damage, whether direct, consequential or incidental, arising out of the use, misuse, or inability to use this product. SAINT-GOBAIN PERFORMANCE PLASTICS DISCLAIMS ALL IMPLIED WARRANTIES OF MERCHANTABILITY AND FITNESS FOR A PARTICULAR PURPOSE.

NOTE: Saint-Gobain Performance Plastics Corporation does not assume any responsibility or liability for any advice furnished by it, or for the performance or results of any installation or use of the product or of any final product into which the product may be incorporated by the purchaser and/or user.